

Ruelco



RUDELCO SELF-CONTAINED

MODEL 5000

1-800-229-7835
RUDELCO@RUDELCO.COM

RUELCO SELF-CONTAINED

FUNCTION

The Ruelco-Self Contained System is designed for the automatic closing of hydraulic actuators where an external power source is not available. The system allows the operator to easily and reliably open the well control actuator while ensuring proper functionality. The low and high pressure accumulators will maintain system pressure through temperature fluctuations. The integrated Pressure Switches allow for precise high and low pressure control of the flow line, and will automatically act to shut down the actuator.

DESIGN FEATURES

- Manifold design with no external tubing on the unit reduces leak points as well as reduces likelihood of damage at jobsite.
- All material is NACE rated using Anodized 6061-T6 Aluminum and 316 Stainless Steel.
- Low and High Pressure relief valves preset to desired pressure to prevent damage to actuator or low pressure equipment.
- Quick exhaust for fast response time
- Solenoid operated control
- 40 micron suction filter to prevent contamination of system.
- Stainless steel gauges with dual scales.
- Integrated Pressure Switches allow for Flow line control without additional components and reduce the tubing required for install.
- Seal material used allows full functionality from -50° F to 180° F (Optional seal materials available upon request).
- High and Low pressure accumulator accommodates for thermal expansion volume changes.
- System is easily opened with use of red anodized latch.
- Sight glass on Tank allows for visual level indication of system.
- Check valve in suction tube ensures a constant prime of the pump.

SPECIFICATIONS

Temperature	Range	-50 F to 180 F	
HP Circuit	Max Pressure	5,000 psi	
LP Circuit	Max Pressure	150 psi	
	Min Pressure	30 psi	
LP Relief Valve	Range	50-150 psi	
	Set point	100 psi	
HP Relief Valve	Range	2,000 - 6,000 psi	
	Set point	5,000 psi	
Reservoir	Capacity	1.6 gallons	
LP Accumulator	Capacity	4.8 cu in	
HP Accumulator	Capacity	6 cu in	
Solenoid	Voltage	12VDC or 24 VDC	
	Wattage	1.8 watts	
	Rating	Class 1 Div 1 A,B,C,D NEMA 4	
Pump	Displacement	.39 cu in/ stroke	
Fuse Plug	Temperature Range	158°F to 283°F	
Pressure Switch	Repeatability	1%	
	Deadband	8%	
	Cv	.13	
	Max Process WP	5,000 psi	
	Burst Pressure	10,000 psi	
	Standard Ranges	1G (50 - 200 psi)	
		1Y (175 - 450 psi)	
2G (450 - 1,750 psi)			
2Y (1,500 - 3,000 psi)			
High Pressure	2P (2,000 - 5,000 psi)		

SCHEMATIC

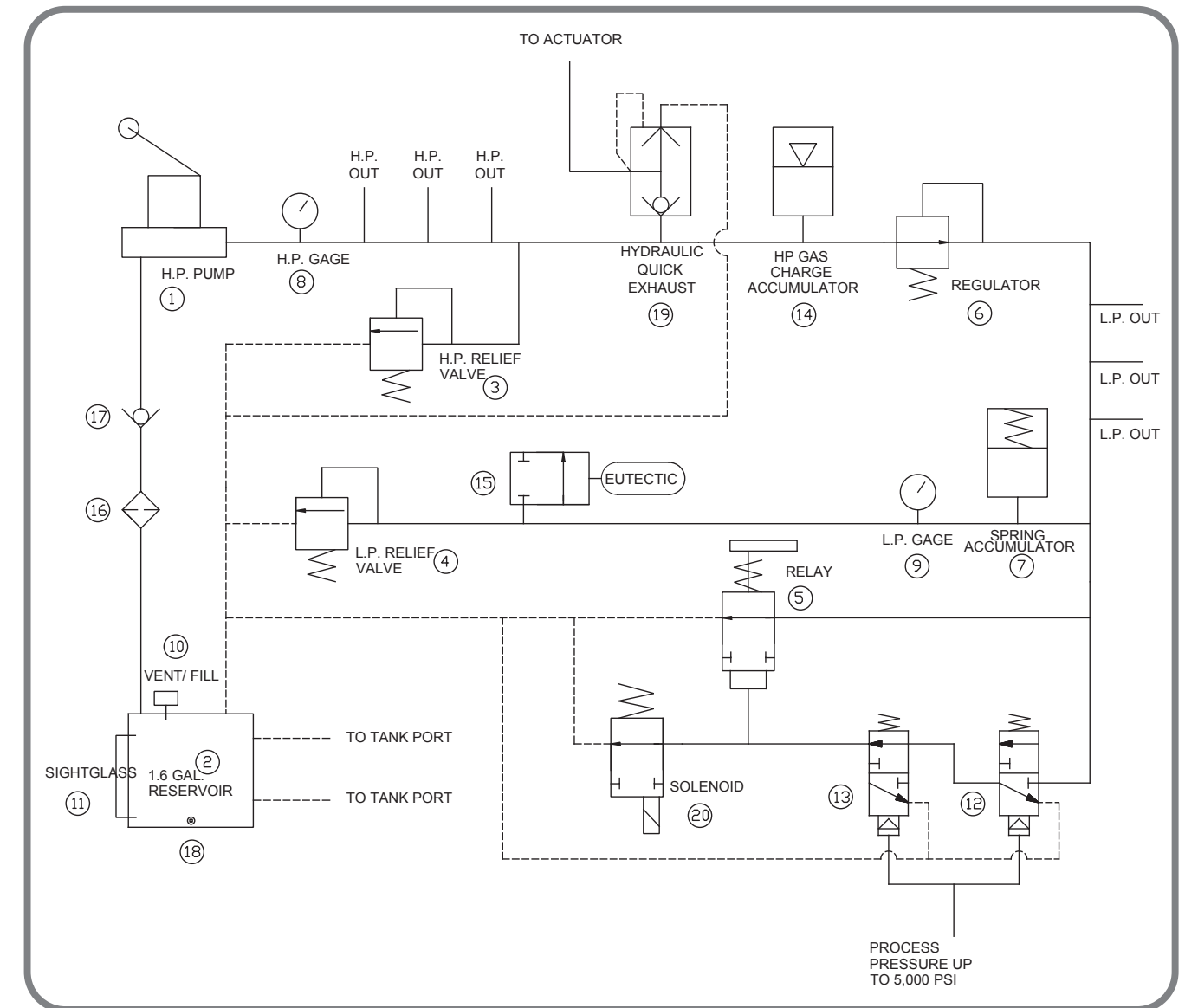

- | | |
|-----------------------------------|---------------------------------------|
| ① High Pressure Hand Pump | ⑪ Sight Glass |
| ② 1.6 Gallon Aluminum Reservoir | ⑫ Low Pressure Switch |
| ③ High Pressure Relief Valve | ⑬ High Pressure Switch |
| ④ Low Pressure Relief Valve | ⑭ 6 cu in HP Gas Charge Accumulator |
| ⑤ Manual Reset Relay | ⑮ Fuse Plug |
| ⑥ Regulator | ⑯ 40 Micron Filter |
| ⑦ 4.8 cu in LP Spring Accumulator | ⑰ Suction Check Valve |
| ⑧ 0 - 5,000 psi Gage | ⑱ Magnetic Drain Plug |
| ⑨ 0 - 60 psi Gage | ⑲ Quick Exhaust |
| ⑩ Vent/ Fill Cap | ⑳ Solenoid Operator (12VDC or 24 VDC) |

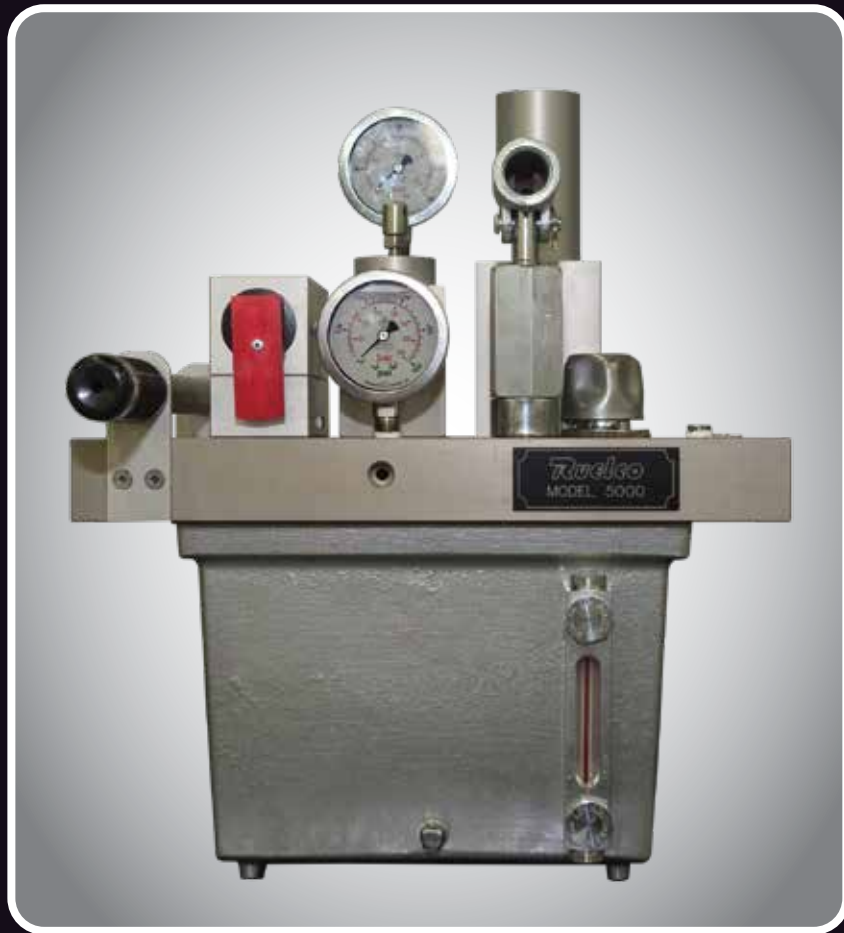

Ruelco

1 209 DISTRIBUTORS ROW
NEW ORLEANS, LA 70123
PHONE: (800) 229-7835
LOCAL: (504) 340-0055
FAX: (504) 340-0056
E-MAIL: SALES@RUELCO.COM